

Wastewater Access Chambers

Innovators of Polymer Products for the Utilities Industry



PWipe and ETI, Inc. have merged
and the new name is:

PWEagle

1550 Valley River Drive
Eugene, OR 97401
800-347-0200

Introduction

The basic concept of a manhole has remained unchanged for more than 150 years. The original function was to provide an access point into the sanitary sewer system large enough to allow two men to enter it and perform inspection and cleaning procedures manually. Over time, due to technology advances, the need for human entry into a manhole to perform routine maintenance operations, has almost disappeared.

The latest Extrusion Technologies, Inc. (ETI) developments follow the technological advances in both function and materials. The Molded Access Products (MAP) division of ETI is built around the need for products consistent with the materials used in most sanitary sewer systems - Polymers or Plastics. For many years, Europeans have been developing and utilizing Polymer technology to manufacture chambers to replace conventional manholes. In 1990, the introduction of the Wastewater Access Chamber (WAC) in Dallas, Texas, began the transition of the U.S. market away from conventional pre-cast, or poured-in-place concrete manholes, toward the technology of the future - Polymers. Since historically the long term performance of concrete, particularly in corrosive environments, has not met its expectations, the time is right! PVC sewer pipe has gained the major portion of the new and rehabilitation collection system market, so it's only natural to make the change to Polymer access chambers. They not only provide a long lasting, cost effective alternative to concrete, but are also effective in minimizing the dangers involved in human entry into confined spaces. What a winning combination!

The Concept

The WAC, Cleanout/Sampling Chamber (CSC) and the WAC 5 are rotational molded Polyethylene chambers designed to provide access into various locations in sanitary or storm drain systems for inspection, sampling and cleaning. The differentiation in the products are the physical size, the pipe sizes they connect to, and the area in the system that they will be installed.

Common Uses For Chambers

- TV inspection access points
- Dead end access
- Cul-de-sac access
- Point repair installation
- Inaccessible easements
- Effluent sampling stations
- Property line cleanout
- Monitoring pits
- Interim access points in long pipe sections



Wastewater Access Chamber (WAC)

Installation

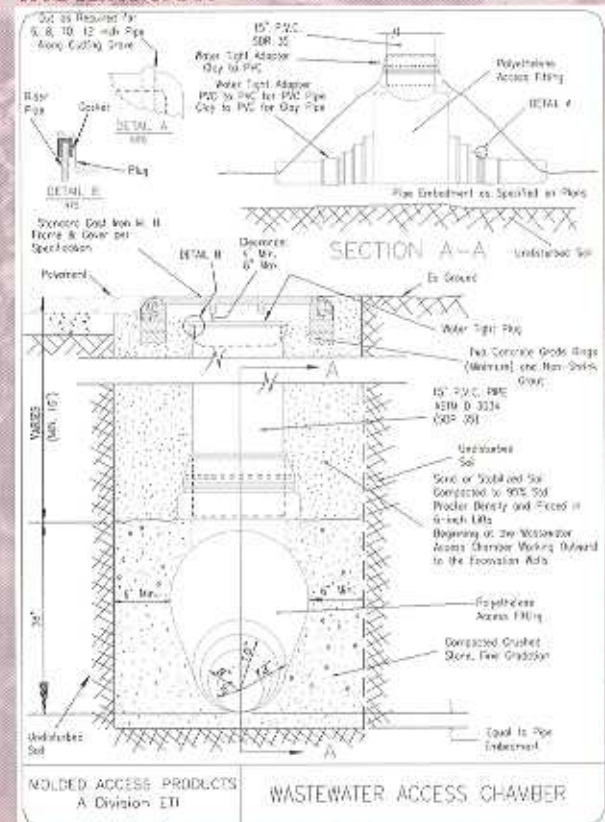

WAC Installation

Wastewater Access Chamber (WAC) Features

Chamber Body

- Sturdy, 3/8" thick, one-piece construction - no welds!
- Smooth interior improves the flow ($n=.009$) through molded inverts
- Large enough for easy insertion of CCTV equipment and high pressure cleaning equipment
- Design resists floating in high ground water conditions
- Light color allows for excellent internal visibility

Dimensions Of Body

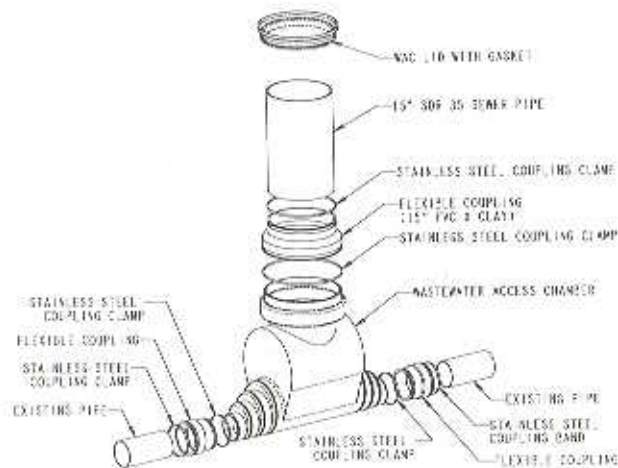

Exploded View of WAC 15

- Length - 43.75" +/- 0.50"
- Height - 37.75" +/- 0.50"
- Width - 18" +/- 0.50"
- Thickness - 0.375" average

15" Riser Pipe On WAC

- Large enough to allow equipment entry, too small for human entry
- Water tight lid with gasket installs in top of riser
- Extends or shortens easily
- Eliminates need for confined space entry procedures and equipment
- Due to 15" size, riser remains independent of standard ring and cover

Surface Treatment

- Standard ring and cover installed on concrete base remains independent of riser pipe - no traffic loading transferred to riser or chamber
- Polyethylene lid with gasket installed in riser, under ring and cover to eliminate inflow into the system - no "dish" or casting to chimney sealing devices required!
- Freeze/Thaw cycle effect minimized
- Street paving adjustments made independently of chamber

Smaller Than Conventional Manholes

- Requires much smaller excavation
- Less disturbance of virgin ground, thus less settling problems
- Amount of repaving reduced
- Less traffic disruption due to reduced installation time
- Does not require heavy equipment to install
- Lower installed cost

WAC 5 (Half Size Version Of WAC) Chamber Body

- Sturdy 1/4" thick, one-piece construction
- Smooth interior improves the flow ($n=.009$) through molded inverts
- Larger than typical cleanouts - more functional
- Accessible to small cleaning equipment and push-rod CCTV equipment
- 6" Inlet/Outlet adaptable to any pipe material through use of flexible couplings
- 10" riser spigot adaptable to 10" SDR 35 pipe
- Leakproof construction
- Light color for easy internal visibility

Dimensions Of Chamber

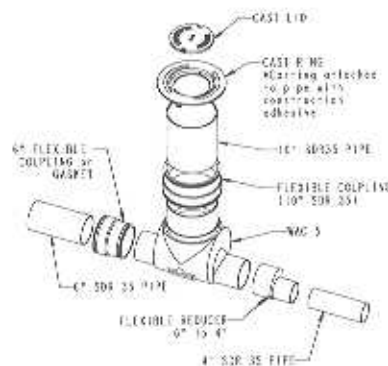

WAC 5 with Pipe and Cast Iron Lid

- Length - 23.10" +/- 0.50"
- Height - 19.00" +/- 0.50"
- Width - 12.00" +/- 0.50"
- Thickness - 0.250" average

10" Riser Pipe On WAC 5

- Large enough to allow sampling accessibility, cleaning and CCTV equipment insertion
- Standard pipe cap may be installed to assure water tight seal
- Easy field depth adjustment
- May be reduced through use of rigid or flexible reducing couplings

Surface Treatment

- Ring and cover may be set on concrete pad, independently of riser pipe - standard pipe cap may be used as water tight seal on riser
- Smaller, locally available ring and cover may be used at surface level

Cleanout/Sampling Chamber (CSC) Features

Chamber Body

- Sturdy 1/4" thick, one-piece construction - no welds!
- Smooth interior improves the flow ($n=.009$) through molded inverts
- Sized to allow access of pressure cleaning equipment and push-rod CCTV equipment
- Riser spigot designed to utilize 12" SDR 35 as well as 12" Ultra-Rib pipe
- Inlets are 4" and 6" SDR 35 direct connections - no extra components required
- 6" outlet directly connected to SDR 35 pipe
- Designed as a "Crow's Foot" to allow two services to be connected through one chamber, cutting main connections in half!

Dimensions of Chamber

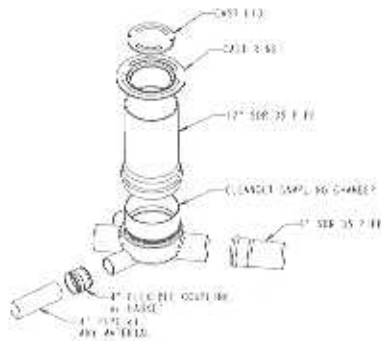

CSC Assembled Configuration

- Length - 26.425" +/- 0.50"
- Height - 14.50" +/- 0.50"
- Width - 21.00" +/- 0.50"
- Thickness - 0.250" average

12" Riser Pipe On CSC

- Sized to keep opening large enough to accept standard pressure cleaning equipment and push-rod CCTV equipment
- Small enough to be installed in sidewalk, yard or easement relatively inconspicuously
- Polyethylene lid with gasket installs in top of riser to provide water tight seal
- SDR 35 or Ultra-Rib may be used as a riser
- Surface opening may be reduced through use of rigid or flexible, reducing couplings
- Riser is cut to proper length at job site by installer



CSC Installation

Surface Treatment

- Standard ring and cover set on a poured concrete pad may be used to gain access
- Smaller ring and covers are available for sidewalk, yard, or easement applications
- Sealed, Polyethylene lid may be buried without ring and cover where complete concealment is desired

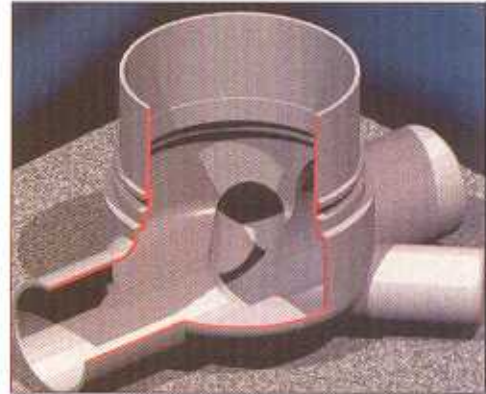

Cut-Away CSC



Sealed Cast Iron Lid



CSC Installation

15" Riser Wastewater Access Chamber Product Specification

General

The Wastewater Access Chamber (WAC) may be used in place of standard concrete manholes, cleanouts, dead-end manholes, or sampling ports, or used in any location in a sewage or storm drainage collection system that requires access for maintenance and inspection equipment, without man entry. The chamber body shall be a one-piece, rotational molded Polyethylene unit that is corrosion resistant, lightweight and designed for use in both traffic and non-traffic locations, where the sewer pipe is 6", 8", 10" or 12" in diameter. The chamber shall be adaptable to clay, cast iron, ductile iron, PVC or concrete pipe through use of flexible couplings.

Material Composition

The WAC shall be rotational molded of 100% virgin Hexene, Linear Low Density, Rotomolding grade Polyethylene meeting the physical standards included on the chart below:



Characteristic	Test Method	Value
Density	ASTM D1505	0.936 grams/cubic cm.
Tensile Strength	ASTM D638	2,490 psi
Flexural Modulus	ASTM D790	87,000 psi
Heat Distortion Temp. @ 66 psi Load	ASTM D648	151 F
Low Temp. Impact @ 125 mils Thick	ARM Standard (B)	45 ft. lbs.
Environmental Cracking Resistance (ESCR), 100 % Igepal	ASTM D1693	> 1000 hrs.

Physical Characteristics

Dimensions

- Length of body shall be 43.75" +/- 0.50"
- Height shall be 37.75" +/- 0.50"
- Width shall be 18.75" +/- 0.50"
- Thickness shall be an average of 0.375"



Other

- Outlets and inlets shall be male (spigot) type extensions connecting to existing piping system with flexible couplings of standard manufacture
- Chamber shall be white or cream color for internal visibility
- Bottom of chamber shall form a channel (invert) with minimal flow disruption
- Top of chamber shall have capability of accepting 15" SDR35 sewer pipe
- Body of chamber shall be a one-piece, rotational molded unit, with no seams or welds
- Included lid of chamber shall act as a water tight plug when inserted into the top of riser pipe with provided gasket
- Spigot end of SDR 35 riser pipe shall be connected to chamber by inserting into open top of unit and sealed with 15" clay x PVC flexible connector

General Features - WAC, CSC and WAC 5

Polyethylene Construction

- Lightweight
- Light color, better visibility on interior
- Lower installation costs
- Leak proof
- Corrosion resistant
- Flexible under load
- Excellent flow characteristics (n=.009)
- Economical compared to conventional manholes
- Adaptable to all pipe materials
- One-piece, molded construction
- Eliminates man entry for maintenance purposes
- Easy cleaning due to smooth interior
- Reusable in other locations

Heavy Wall, Polyethylene Construction

- Easy handling at job site
- Withstands earth loads
- Resistant to shipping damage
- Resists damage from mechanical cleaning equipment
- Smooth interior reduces cleaning frequency
- Proven material history
- Excellent Environmental Stress Corrosion Resistance (ESCR)
- Excellent corrosion resistance

Inlets/Outlets On WAC And CSC Are Designed To Accommodate Standard Pipe Connections With Flexible Connectors

- Conventional installation procedures
- Leak proof joints
- No special components required
- No special tools required

Warranty

All products sold are subject to the following warranty: Molded Access Products (MAP) warrants for a period of one year from date of delivery to the original purchaser, that the product is free from defects in materials and workmanship. MAP makes no other warranty of any kind, express or implied, in fact or in law, including without limitation, the warranty of merchantability or the warranty of fitness for a particular purpose, other than the limited warranty set forth above. Every claim under this warranty shall be deemed waived, unless in writing and received by MAP within thirty (30) days of the date the defect to which each claim relates is discovered, or should have been discovered.

Limitation of Liability

It is expressly understood and agreed that the limit of MAP's liability shall be at MAP's sole option, repair or resupply of a like quantity of nondefective product, and that MAP shall have no such liability except where the damage results solely from breach of MAP's warranty. It is also agreed that MAP shall not be liable for any incidental, consequential, or other damages for any alleged negligence, breach of warranty, strict liability, or any other theory, other than the limited liability set forth above. The physical (or chemical) properties of MAP products represent typical average values obtained in accordance with accepted test methods, and are subject to normal manufacturing variations. They are supplied as a technical service and are subject to change without notice.

Customer Service Centers:

- Oregon: 800-347-0200
Missouri: 800-341-0053
West Virginia: 800-624-3111

**PWPipe and ETI, Inc. have merged
and the new name is:**

PWEagle

1550 Valley River Drive
Eugene, OR 97401
800-347-0200